

**Pic-A-Vac**

**Model: MC832085  
MC833085  
MC832105  
MC833105  
MC832130  
MC833130**

**OPERATION**

**SERVICE**

**PARTS**

**CARE**

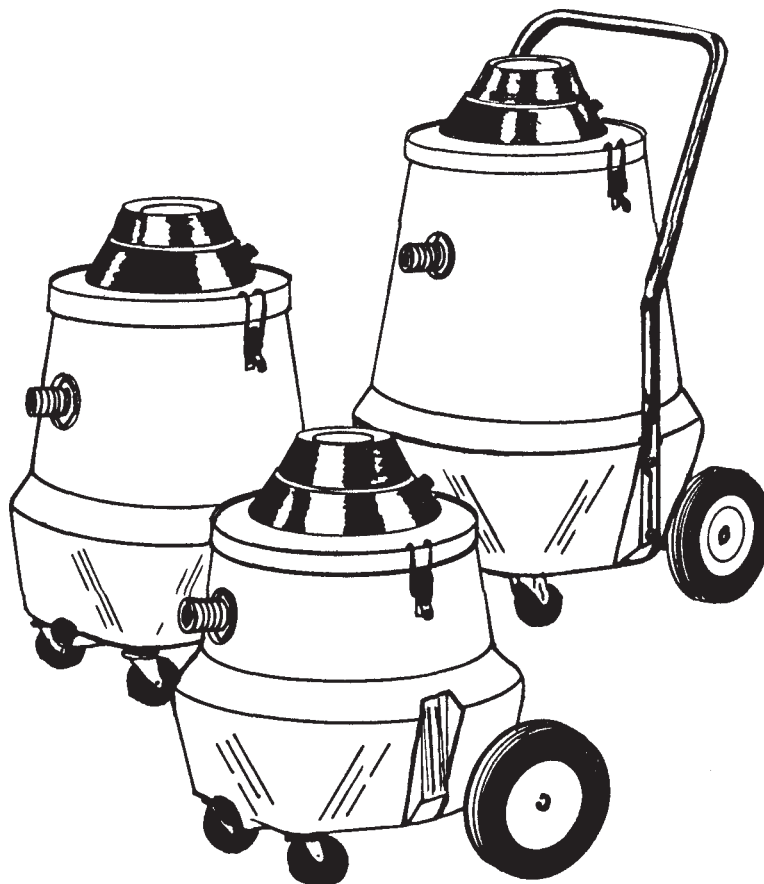

Revised 8/01

***Minuteman***<sup>®</sup>

# FOR COMMERCIAL USE ONLY

## IMPORTANT SAFETY INSTRUCTIONS

When using an electrical appliance, basic precautions should always be followed, including the following:

### READ ALL INSTRUCTIONS BEFORE USING

#### **WARNING** - To reduce the risk of fire, electric shock, or injury:

- Do not leave appliance when plugged in. Unplug from outlet when not in use and before servicing.
- To avoid electrical shock, do not expose to rain, store indoors.

#### **WARNING:**

To reduce the risk of electrical shock - Do not use on wet surfaces. Do not expose to rain. Store indoors.

- Do not allow to be used as a toy. Close attention is necessary when used by or near children.
- Use only as described in this manual. Use only manufacturer's recommended attachments.
- Do not use with damaged cord or plug. If appliance is not working as it should, has been dropped, damaged, left outdoors, or dropped into water, return it to a service center.
- Do not pull or carry by cord, use cord as a handle, close a door on cord, or pull cord around sharp edges or corners. Do not run appliance over cord. Keep cord away from heated surfaces.
- Do not unplug by pulling on cord. To unplug, grasp the plug, not the cord.
- Do not handle plug or appliance with wet hands.
- Do not put any object into openings. Do not use with any opening blocked; keep free of dust, lint, hair, and anything that may reduce air flow.
- Keep hair, loose clothing, fingers, and all parts of body away from openings and moving parts.
- Do not pick up anything that is burning or smoking, such as cigarettes, matches, or hot ashes.
- Do not use without dustbag and/or filters in place.
- Turn off all controls before unplugging.
- Use extra care when cleaning on stairs.
- Do not use to pick up flammable or combustible liquids such as gasoline or use in areas where they may be present.
- Connect to a properly grounded outlet only. See grounding instructions.

### SAVE THESE INSTRUCTIONS

## INSPECTION

Carefully unpack and inspect your machine for shipping damage. Each unit is tested and thoroughly inspected before shipment, and any damage is the responsibility of the delivery carrier who should be notified immediately.

## ELECTRICAL - 115 Volt

This machine is designed to operate on a standard 15 amp, 115 volt, 60 hz, AC circuit. Voltages below 105 volts AC or above 125 volts AC could cause serious damage to the motor.

## ELECTRICAL - 240 Volt

This machine is designed to operate on a standard 10 amp, 230 volt, 50 hz, AC circuit.

## WARNING

Electric motors can cause explosions when operated near explosive materials or vapors. Do not operate this machine near flammable materials such as solvents, thinners, fuels, grain dust, etc.

## GROUNDING INSTRUCTIONS

This appliance must be grounded. If it should malfunction or breakdown, grounding provides a path of least resistance for electric current to reduce the risk of electric shock. This appliance is equipped with a cord having an equipment-grounding conductor and grounding plug. The plug must be plugged into an appropriate outlet that is properly installed and grounded in accordance with all local codes and ordinances.

## DANGER

Improper connection of the equipment-grounding conductor can result in a risk of electric shock. Check with a qualified electrician or service person if you are in doubt as to whether the outlet is properly grounded. Do not modify the plug provided with the appliance — if it will not fit the outlet, have a proper outlet installed by a qualified electrician.

This machine is for use on a nominal 120 volt circuit and has a grounding plug that looks like the plug illustrated in Sketch A. Make sure that the machine is connected to an outlet having the same configuration as the plug. No adapter should be used with this appliance.

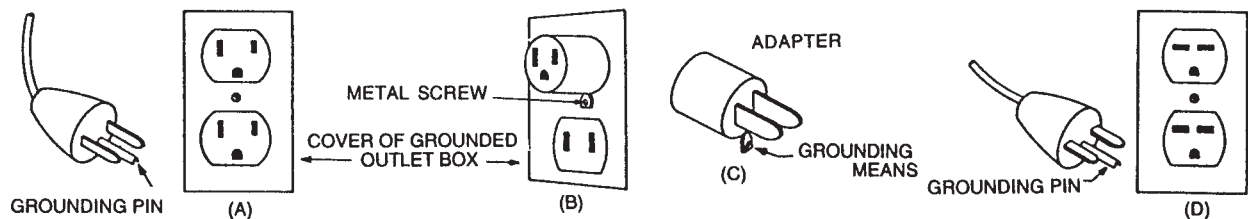

## **WARNING**

This vacuum may contain potentially hazardous dust depending on its application. Special handling of contaminated disposal bags and filters is recommended. Disposal must be in compliance with local EPA regulations

## **USER MAINTENANCE INSTRUCTIONS**

All service and repair should be performed by qualified vacuum service representative or electrician. No user serviceable components are employed in the electrical vacuum lid head assembly. No lubrication of the motor is required.

## **CLOTH BAG & HOSE ASSEMBLY**

Cloth bag and hose assembly are user maintenance items and can be replaced when worn out. For optimum performance, empty and clean filter bag regularly. A clogged and dirty bag restricts the flow of air and results in reduced vacuum. The hose assembly can be maintained by wiping off with a dampened cloth of mild liquid soap and water, then allowed to dry.

## **CORD STORAGE**

While not in use storage can be accomplished by winding cord around motor lid assembly. Cord should be completely unwound from lid assembly during operation.

- Do not use with damaged cord or plug. If appliance is not working as it should, has been dropped, damaged, left outdoors, or dropped into water, return to service center.
- Do not pull or carry by cord, use cord as handle, close a door on cord, or pull cord around sharp edges or corners. Do not run appliance over cord. Keep cord away from heated surfaces.
- Do not unplug by pulling cord. To unplug, grasp the plug, not the cord.
- Do not handle plug or appliance with wet hands.
- Always unplug the machine when removing the motor head off the tank.  
This equipment should be stored indoors and not exposed to rain.

Always unplug the machine when removing the motor head off the tank. This equipment should be stored indoors and not exposed to rain.

# HEAD AND TANK ASSEMBLY INSTRUCTIONS

Install float and float cage to the head assembly. When installing float, make sure the weighted bolt in the float faces away from the vacuum head. The float cage snaps on the head assembly and is then secured using 1/4-20 bolt, washer, and nut provided in the hardware package.

## Handle Installation - 16 Gallon Tank Only

Install handle struts to the tank with snap button facing in towards the tank. The screws provided will pass through struts and screw into the tank's threaded holes. The washers and nuts, also provided, are fastened on the inside of the tank. When both struts are attached, handle will slide over struts. Make certain snap buttons lock into holes located on handle.

## TO MAKE VACUUM READY FOR USE, FOLLOW THESE STEPS:

1. Set filter bag assembly in tank.
2. Set head on top of assembly installed in Step 1 and clamp onto tank with clamps attached to tank. Make sure head is positioned and centered correctly on tank.
3. Attach hose to intake connector on front of tank.
4. Check drain plug to make sure it is securely in place. To make plug larger in diameter, turn lever on it clockwise: to make it smaller, turn lever in opposite direction.
5. Attach vacuum cleaner attachment to loose end of hose.
6. Plug cord into electrical outlet of correct voltage. Push switch to "On" position when ready to commence work.

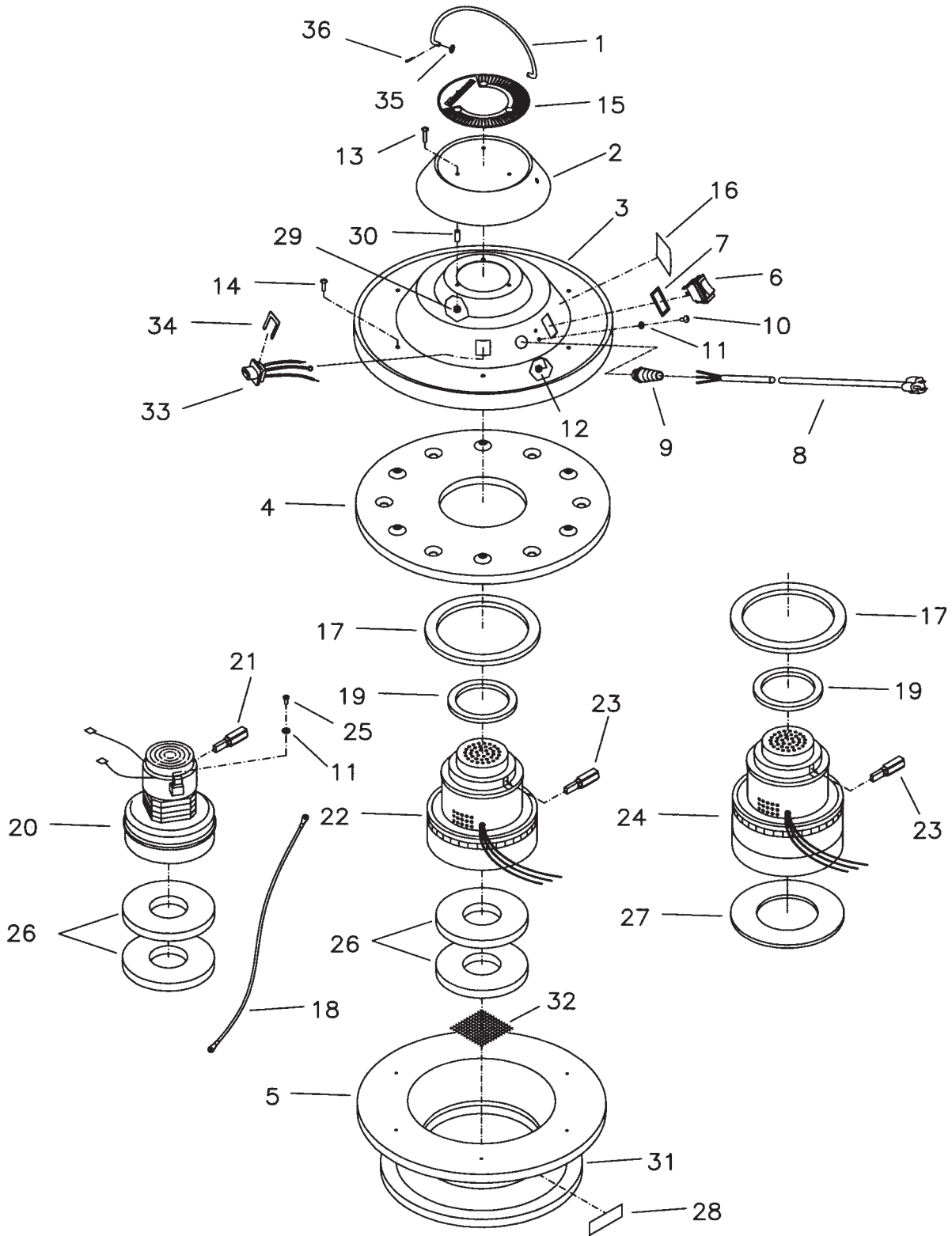

## Parts List

Item	Part #	Qty	Description
1	827743	1	Handle
2	831480	1	Motor Cap
3	831518	1	Cove, Motor
4	831492	1	Shroud, Motor
5	831482	1	Pan, Motor
6	809754	1	Switch, Motor
6A	809755	1	Switch
7	450088	1	Spacer, Switch
8	381020	1	Gray Cord Set 16-3 50'
9	833237	1	Strain Relief
10	712810	2	SCR-MC 10-24 x .37 STPL
11	711553	2	WSR-Internal Lock #10
12	712638	3	Nut-Hex 10-24 SS Nyloc
13	712823	3	SCR-THMS 10-24 x 1.00 STPL
14	711126	6	SCR-ST-B 10 x .75 STPL
15	715105	1	Decal, P/V 105
15A	715085	1	Decal, P/V 85
15B	715130	1	Decal, P/V 130
16	828817	1	Decal, Warning Label
17	831478	1	Gasket, Neop 6 x 7.5 x .37
18	740116	1	Ground Wire
19	831484	1	Gasket, 3.5 x 4.5 x .31
20	380001	1	Vac Motor, Bypass 115V-85
20A	380054	1	Vac Motor, Bypass 240V-85
21	380028	2	Brush, Carbon - 85
22	255039	1	Vac Motor, Bypass 115V-105
22A	255040	1	Vac Motor, Bypass 240V-105
23	255008	2	Brush, Carbon - 105
24	831524	1	Vac Motor, 3 Stage 115V-130
24A	831526	1	Vac Motor, 3 Stage 240V-130
25	711124	1	SCR-ST-B 10 x .37
26	828995	2	Gasket, Neop 2.5 x 6 x .62
27	831626	1	Gasket 4 x 7.37 x .250
28	831576	1	Decal Warning Check Screen
29	712908	3	Nut-Flanged Wizz 10-24
30	831652	3	Spacer
31	833794	1	Gasket Seal 11.16 x 13.16
32	807051	1	Screen Filter SS 85/105
32A	832317	1	Screen Filter SS 130
33	831801	1	Receptacle
34	831801-1	1	Receptacle Clip
35	711505	2	WSR-Flat 1/4
36	711803	1	Cotter Pin

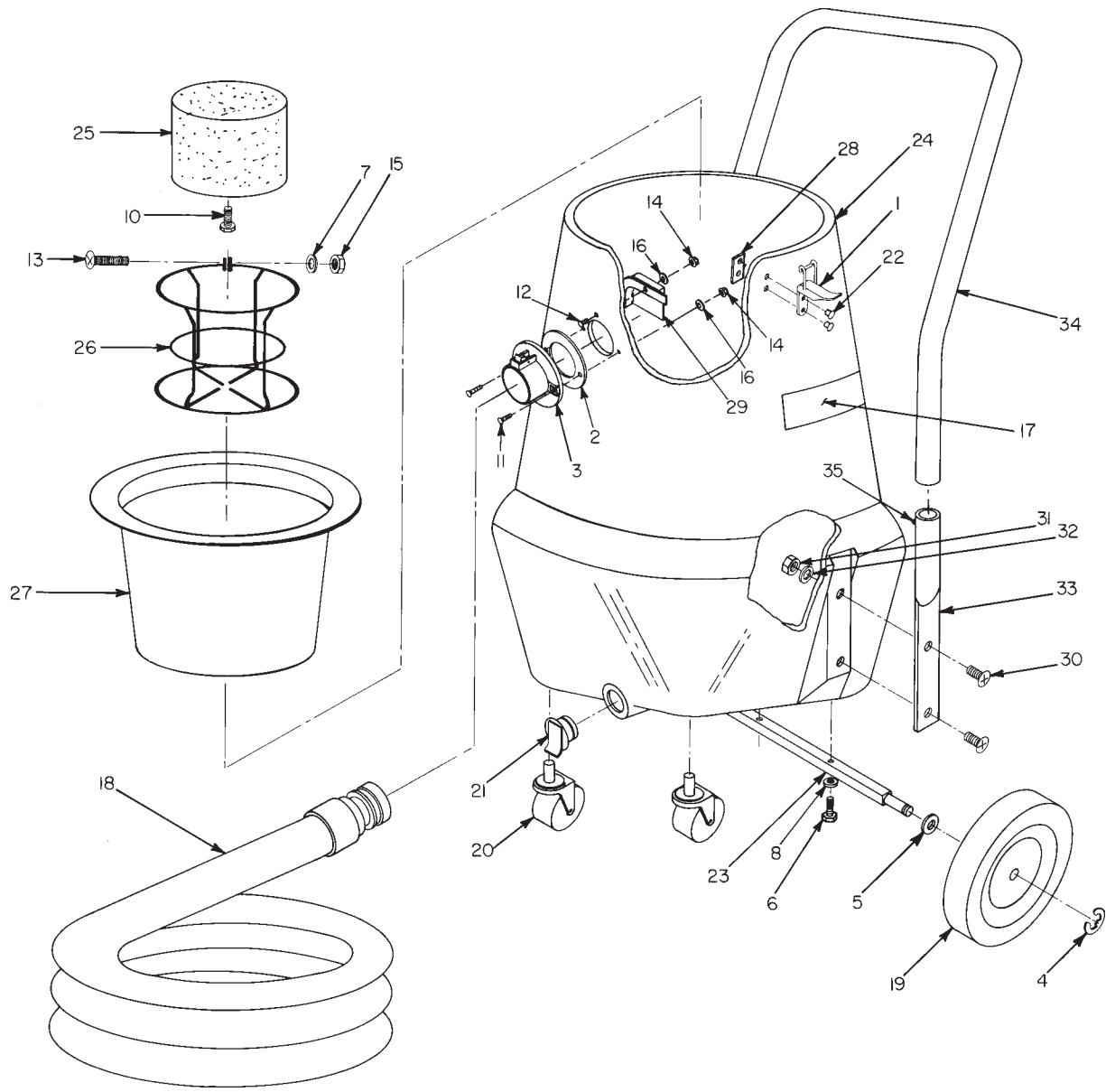



## Parts List

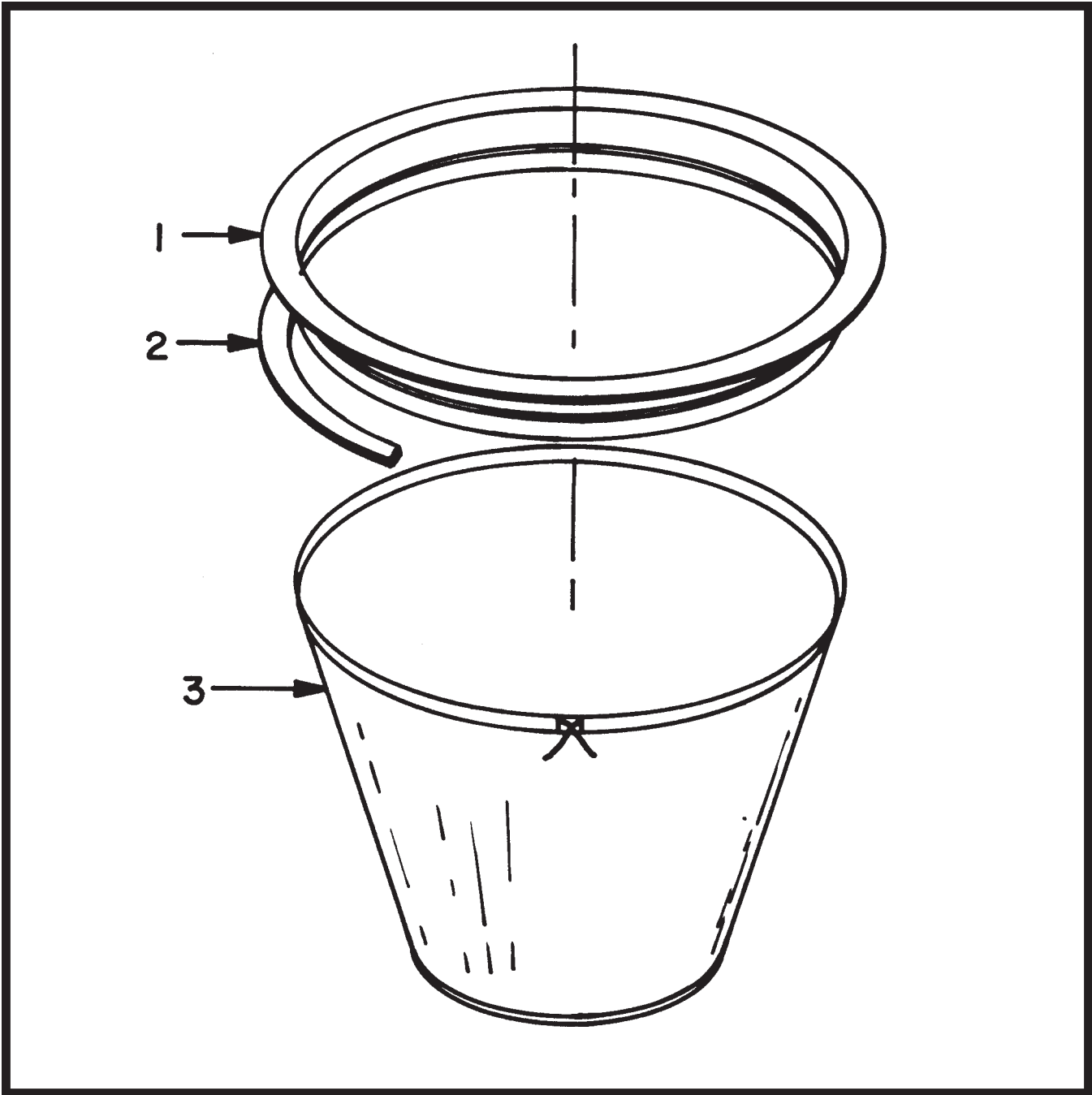

Item	Part #	Qty	Description
1	390035	2	Latch
2	390087	1	Gasket Diecut
3	390100	1	Intake Assy
3A	390110	1	Intake Assy Aluminum
4	711713	2	Retaining Ring-E Ext .50
5	711524	2	WSR-Wave .52 x .87 x .01
6	712569	2	SCR-MC 1/4-20 x 1.50 SS
7	No Longer Used		
8	711591	2	WSR-Rubber
9			
10	Included in Item 25		
11	712532	2	SCR-MC 10-24 x 1.00 SS
12	712819	1	SCR-MC 10-24 x .75 NIPL
13	712569	1	SCR-MC 1/4-20 x 1.50 SS
14	712638	3	Nut-Hex 10-24 SS Nyloc
15	711425	2	Nut-Flanged Wizz 1/4-20
16	711274	3	WSR SS #10
17	715382	1	Decal "Minuteman"
18	800303	1	Hose Assy 1-1/2 x 10 (5,10 Gal)
18A	800317	1	Hose Assy 1.5 x 10 (16 Gal)
19	900008	2	Wheel, 8.00 Dia
20	804457	2	Caster 3"
21	833316	1	Drain Plug
22	828894	4	Pop Rivet
23	829837	1	Axle
24	833945	1	Tank w/Sockets, 5 Gal
24A	833950	1	Tank w/Sockets, 10 Gal
24B	833956	1	Tank w/Sockets, 16 Gal
25	830987	1	Float Assy
26	833454	1	Float Cage
27	833795	1	Filter Bag Assy
28	833831	2	Clamp Back Plate
29	900035	1	Deflector, Intake
30	710399	4	SCR-MC 3/8-16 x 1.00 STPL
31	711439	4	Nut-Flanged Wizz 3/8-16
32	No Longer Used		
33	831121	2	Handle Support
34	831614	1	Handle
35	831629	2	Snap Button
***	832005	xxx	5 Gal Tank Assy Complete
***	832010	xxx	10 Gal Tank Assy Complete
***	832016	xxx	16 Gal Tank Assy Complete



**Parts List**

Item	Part #	Qty	Description
1	830626	1	Filter Ring
2	830634	1	Gasket
3	833797	1	Wet/Dry Filter Bag
	833795	xx	Wet/Dry Filter Bag Assy
	833785	xx	Wet Filter Bag Assy
	700042	xx	Paper Filter Bag 6/Pkg
	833798	xx	Wet Filter Bag Only

# OPTIONAL WET/DRY FLOOR CLEANING KIT 807180

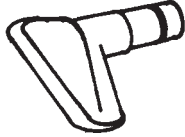
	Part #	Description
	761228	1 1/2" X 54" Wand Assembly
	800124	Utility Nozzle
	800605 800616 800615	14" Squeegee Replacement Blades 4/set Fastening Band
	601032 17916	Rug Nozzle Replacement Brush

# LIMITED WARRANTY

Minuteman International, Inc. warrants to the original purchaser/user that this product is free from defects in workmanship and materials under normal use and service for a period of three years from date of purchase. In addition, Minuteman International, Inc. will, at its option, honor labor warranty claims for the first 12 months from date of sale, provided such claims are submitted through and approved by factory authorized repair stations. Minuteman International, Inc. will, at its option, repair or replace without charge, except for transportation costs, parts that fail under normal use and service when operated and maintained in accordance with the applicable operation and instruction manuals.

This warranty does not apply to normal wear, or to items whose life is dependent on their use and care, such as belts, cords, switches, hoses, rubber parts, electrical motor components or adjustments. Parts not manufactured by Minuteman International, Inc. such as engines, batteries, battery chargers, hydraulic pumps, and tires are covered by and subject to the warranties and/or guarantees of their manufacturers. Please contact Minuteman International, Inc. for procedures in warranty claims against these manufacturers.

**Special warning to purchaser** — Use of replacement filters and/or prefilters not manufactured by Minuteman International, Inc. or its designated licensees, will void all warranties expressed or implied.

A potential health hazard exists without exact original equipment replacement.

All warranted items become the sole property of Minuteman International, Inc. or its original manufacturer, whichever the case may be.

Minuteman International, Inc. disclaims any implied warranty, including the warranty of merchantability and the warranty of fitness for a particular purpose. Minuteman International, Inc. assumes no responsibility for any special, incidental or consequential damages.

This limited warranty is applicable only in the U.S.A. and Canada, and is extended only to the original user/purchaser of this product. Customers outside the U.S.A. and Canada should contact their local distributor for export warranty policies. Minuteman International, Inc. is not responsible for costs or repairs performed by persons other than those specifically authorized by Minuteman International, Inc. This warranty does not apply to damage from transportation, alterations by unauthorized persons, misuse or abuse of the equipment, use of non-compatible chemicals, or damage to property, or loss of income due to malfunctions of the product.

If a difficulty develops with this machine, you should contact the dealer from whom it was purchased.

This warranty gives you specific legal rights, and you may have other rights which vary from state to state. Some states do not allow the exclusion or limitation of special, incidental or consequential damages, or limitations on how long an implied warranty lasts, so the above exclusions and limitations may not apply to you.

## **Minuteman**<sup>®</sup>

**World Headquarters**  
Minuteman International, Inc.  
111 South Rohlwing Road  
Addison, Illinois 60101

(630) 627-6900  
FAX (630) 627-1130

Minuteman Canada, Inc.  
2210 Drew Road  
Mississauga, Ontario  
L5S 1B1

(905) 673-3222  
FAX (905) 673-5161

987309  
Printed in U.S.A.